

Product Male cable connector with cable clamp, cable outlet 6-7,8 mm
Area M16 connectors IP 67 serie 423

Pole 8 DIN
Article number 99 5671 00 08

illustration



scale drawing



Contact Arrangement

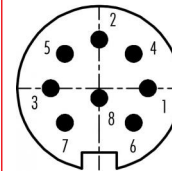

	X	Y
1	3,50	0,00
2	0,00	3,50
3	-3,50	0,00
4	2,47	2,47
5	-2,47	2,47
6	2,47	-2,47
7	-2,47	-2,47
8	0,00	-0,70

Attenuation characteristic

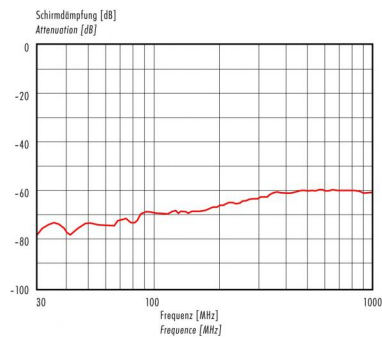

You can find the item description and assembly instruction on the next page.

Technical data

Common values

Connector Design	Male cable connector
Connector locking system	Screw
Termination	solder
Wire gauge (mm)	0,75 mm ²
Wire gauge (AWG)	20
Cable outlet	6 - 7,8 mm
Upper temperature	+95 °C
Lower temperature	-40 °C

Material

Material of contact	CuZn (brass)
Contact plating	Ag (silver)
Material of contact body	PBT (UL 94 V-0)
Material of housing	CUZn (brass nickel plated)

Cable data

Contacts 8 DIN, male cable connector with cable clamp, shieldable, cable outlet 6 - 8 mm, silver plated contacts

Electrical values

Rated voltage	60 V
Rated impulse voltage	500 V
Pollution degree	I
Overvoltage category	I
Material group	III
Rated current (40°C)	5 A
Volume resistivity	≤ 5 mΩ
EMV compliance	shielded
Degree of protection	IP 67
Mechanical operation	>500 mating cycles



Product Area	Male cable connector with cable clamp, cable outlet 6-7,8 mm M16 connectors IP 67 serie 423	Pole Article number	8 DIN 99 5671 00 08
--------------	---	---------------------	------------------------

Item description

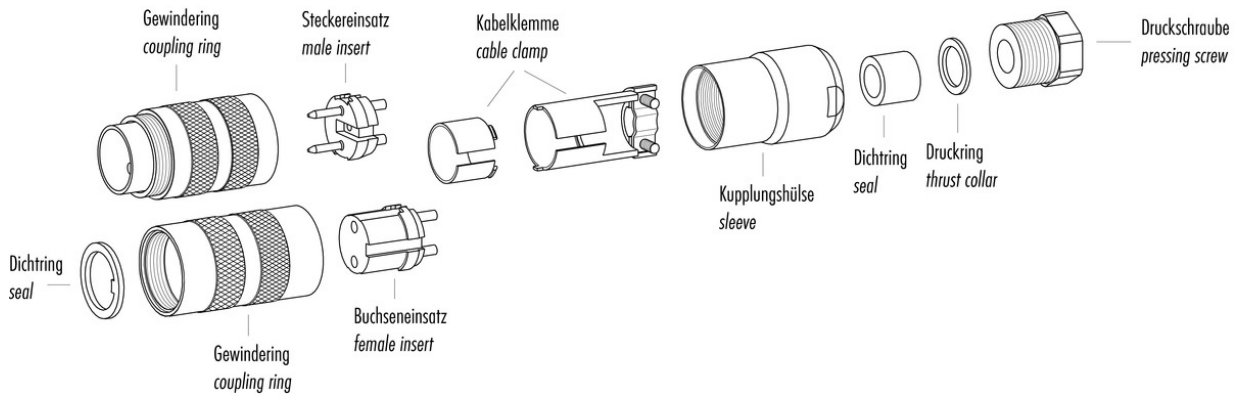

Installation instructions / Mounting cutout

Gerade Version

(Ausführung mit Schirmklemmring)

1. Druckschraube, Klemmkorb, Dichtung, Distanzhülse und ersten Schirmklemmring auffädeln.
2. Litzen abisolieren, Schirm aufweiten und zweiten Schirmklemmring auffädeln.
3. Litzen anlöten, Distanzhülse montieren, die beiden Klemmringe mit dem Schirm zusammenschieben und überstehenden Schirm abschneiden.
4. Übrige Teile gemäß Darstellung montieren.

Straight version

(Version with shield clamping ring)

1. Bead pressing screw, pinch ring, seal, distance shell and first shield clamping ring on cable.
2. Strip wires, widen shield and bead second shield clamping ring.
3. Solder wires, snap distance shell, push the two shield clamping rings together and cutt off projecting shielding braid.
4. Assemble remaining parts according to picture.

