

External Miniature Rectangular, Removable Contacts

Contact Arrangements

Dimensions are for reference only and are subject to change. Outline drawings on request. Views are rear (wiring end) of female inserts. (Male inserts are opposite.)

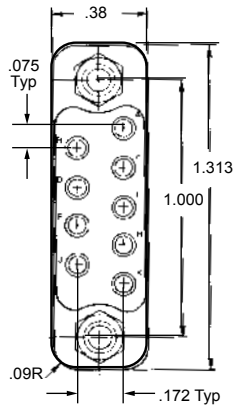

XAC 9

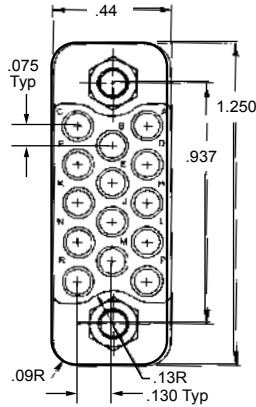

XAC 14

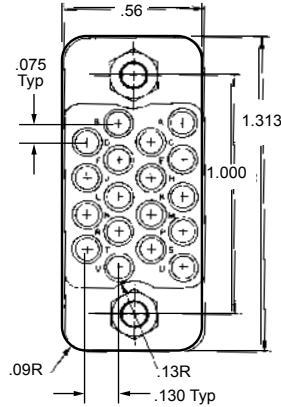

XAC 18

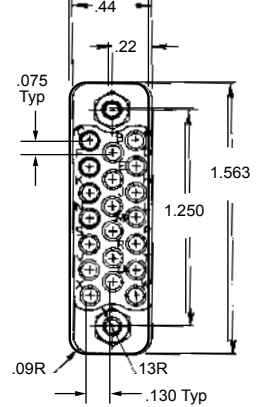

XAC 20

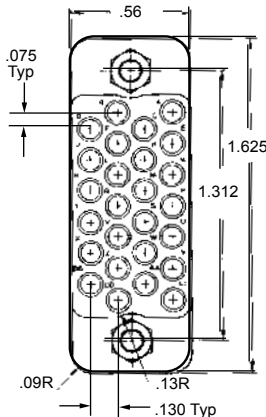

XAC 26

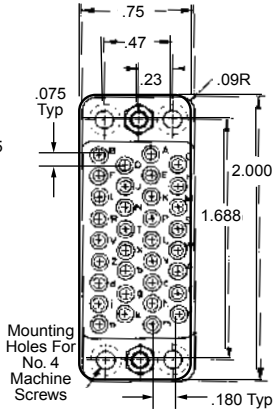

XAC 34*

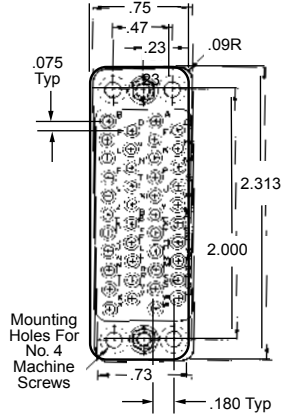

XAC 42

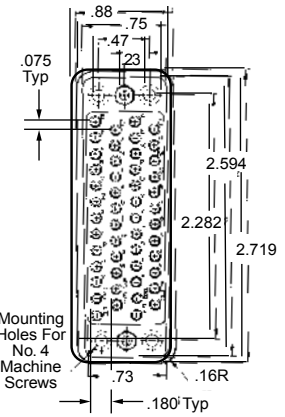

XAC 50*

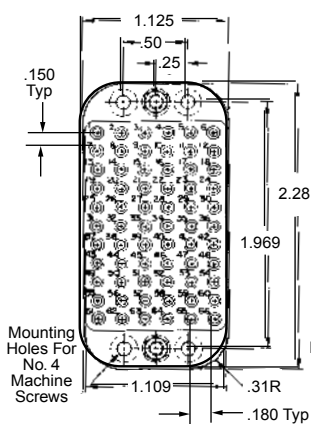

XAC 66

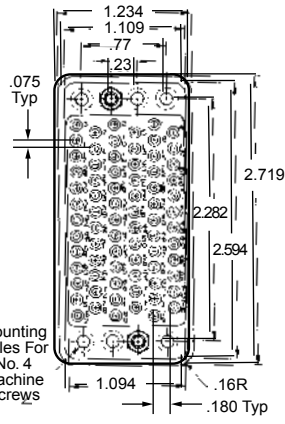

XAC 75

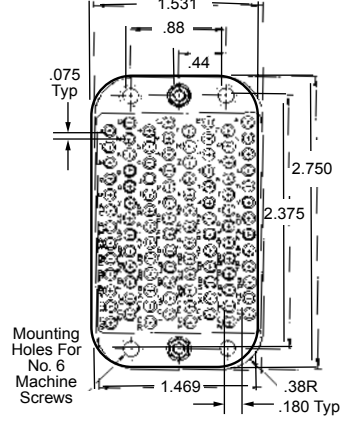

XAC 104*

*For numerical contact identification instead of alphabetical, order XNAC**P or S available in sizes 34, 50, and 104.

Sizes 66 and 75 have numerical contact identification as standard.

The spacing, arrangement, and identification of contacts of the XAC inserts are the same as those found on the Series MRAC removable contact connectors for the same number of contacts.