

Ø .125
[3.18]
4 HOLES

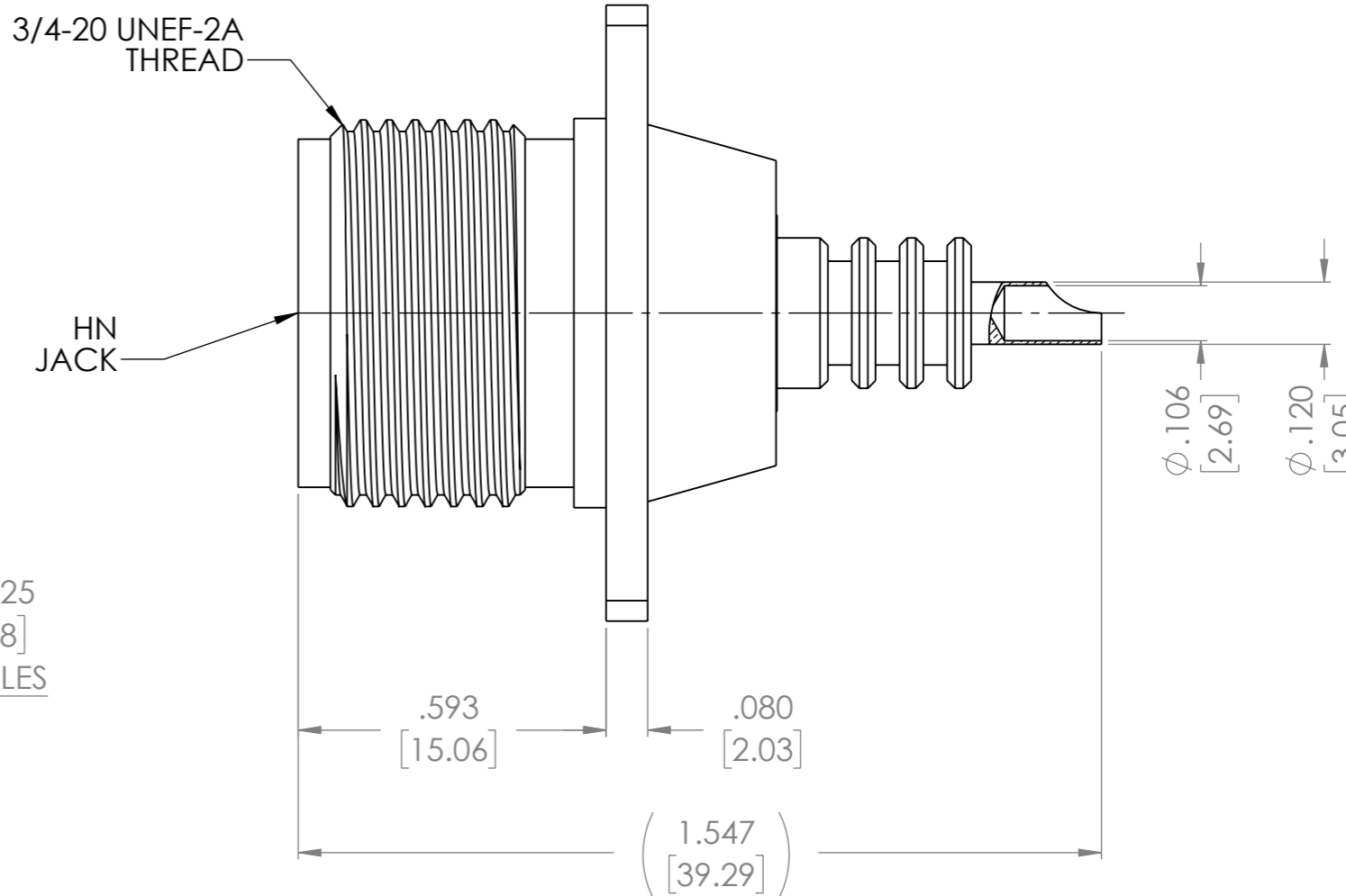

NOTES:

- 1. ASSEMBLED CONNECTOR INTERFACE IS DESIGNED IN ACCORDANCE WITH MIL-STD-348.

CAP (BLACK)	Vinyl, Red	N/A
BODY	BRASS PER ASTM B16, C36000 ALLOY, TEMPER H02	SILVER PLATE PER ASTM B700
INSULATOR	TEFLON PER ASTM D1710, TYPE 1, GRADE 1, CLASS A.	N/A
CONTACT	BERYLLIUM COPPER PER ASTM B196, C17300, TEMPER TD04	SILVER PLATE PER ASTM B700
DESCRIPTION	MATERIAL	FINISH
Table 1		

PROPRIETARY AND CONFIDENTIAL
THE INFORMATION CONTAINED IN THIS DRAWING IS THE SOLE PROPERTY OF DELTA ELECTRONICS MFG CORP. ANY REPRODUCTION IN PART OR AS A WHOLE WITHOUT THE WRITTEN PERMISSION OF DELTA ELECTRONICS MFG CORP. IS PROHIBITED.
FILE NAME: 1613000A401-000T

UNLESS OTHERWISE SPECIFIED:		NAME	DATE
DIMENSIONS ARE IN INCHES		DRAWN	ADK 5/30/2024
TOLERANCES:		CHECKED	BJM 5/30/2024
FRACTIONAL ± 1/64		ENG APPR.	BJM 5/30/2024
ANGULAR: MACH ± 1° BEND ± 1°		COMMENTS:	
TWO PLACE DECIMAL ± .01			
THREE PLACE DECIMAL ± .005			
SURFACE FINISH = 63			
MAX. CORNER BREAKS = .004			
THIRD ANGLE PROJECTION			
MATERIAL	SEE TABLE		
FINISH	SEE TABLE		
SCALE: 3:1			

DELTA ELECTRONICS MFG CORP.		
BEVERLY, MA 01915		
www.deltarf.com / Ph: 978-927-1060 / Fax: 978-922-6430		
TITLE: HN STRAIGHT RECEPTACLE JACK SOLDER POT CONTACT		
SIZE	DWG. NO.	REV
B	1613000A4001-000	-
CODE ID - 00795	WEIGHT: 42.67 g	SHEET 1 OF 1